

SENSORFACT

Installation Manual

Smart monitoring for the industry



Go to www.sensorfact.eu/help for installation videos and useful knowledge base articles.

Contents

1. Before you start: preparation	3
How the system works.....	3
Installation plan and approach.....	3
Network configuration.....	4
Items needed for installation.....	4
Security context.....	4
2. Sensorfact Software	5
Logging in.....	5
Viewing data.....	5
Installation feedback.....	5
3. Bridges	6
Installation steps.....	7
4. Current sensors	9
Installation steps.....	9
5. Pulse sensors	11
Determine the suitable connection method.....	11
Items needed for installation.....	11
Installation steps.....	12
Additional commissioning (only if advised by Sensorfact).....	13
6. Troubleshooting guide	15

1. Before you start: preparation

This manual guides you through the installation of the hardware components of the Sensorfact energy management system. Once the installation is complete, you will be able to monitor your energy consumption in real-time and over time, providing you with instant, valuable insights. As part of the onboarding process, you will receive expert savings advice approximately two months after the installation is completed.

Go to www.sensorfact.eu/help for installation videos and useful knowledge base articles.

How the system works

The Sensorfact energy hardware consists of bridges and current sensors of different sizes. The current sensors measure the consumed energy of a single machine. The pulse sensors monitor the consumption measured with a different utility meter that provides a signal. The sensors wirelessly transmit the measurement data to a bridge, which then sends the measurement data to our cloud software platform. Subsequently, in the Sensorfact Software you can track this consumption over time to gain valuable insights.



For questions about the installation and the display of your data, please contact your Onboarding Representative or e-mail support@sensorfact.eu.

Installation plan and approach

Before installing, check the inventory list to see to which sensors your machines (and meters) are linked-up with. Then, consider the below, taking the max. reach of the bridges (15 m.) into account. Every location is different so the distance can change per location. If you need more bridges, you can easily order more in our [webshop](#).

- Decide whether to first install the bridges or the sensors.
 - If you know exactly the locations of the sensors, we recommend starting with the bridges, as you will already know the distance between the bridges and sensors.
 - If you will determine the locations of the sensors in practice, we recommend to firstly install the sensors. Subsequently, you can better decide the location of the bridges.
- Location of sensors
 - It is recommended to install the sensors on individual machines, as this enables optimal identification of energy savings.
 - Aim to mount the transmitters outside the cabinet to ensure reach of the wireless signal.
- Location of bridges
 - An electrical outlet has to be present near to the location where a bridge is mounted.
 - Do not mount a bridge within a distribution cabinet, to ensure a good internet connection.

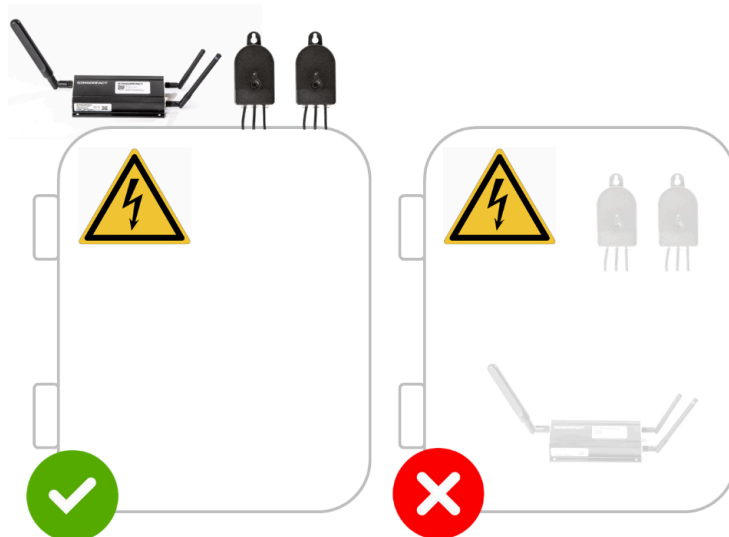

Aim to install the clamps of the current sensors within a distribution cabinet. Then, mount the transmitters of the sensors and the bridge outside the cabinet

Network configuration

If you are connecting the bridges via a local network (NB. not relevant for LTE/4G connections), please guarantee internet connectivity by properly configuring your ports/firewalls. The bridges cannot deliver the data to our cloud platform if this is not done correctly. The IP addresses, ports and protocols in [this link](#) should be accessible. Ask your IT department for help if needed.

If MAC-addresses are needed, your onboarding representative can deliver these to you.

If you will use Wi-Fi, Sensorfact has already configured your bridges if you have shared your WiFi-credentials upfront the hardware shipment in the shipment email.

Items needed for installation

You will need the following items for the installation:

- The bridges and sensors
- The inventory list provided in the package (incl. familiarity with the names/functions of the machines or meters)
- Connecting materials such as screws, double-sided tape or tie wraps
- A cleaning cloth

Security context

The security of your system begins with the physical protection of its components. Our devices, including sensors and bridges, are designed with robust software and encrypted communication protocols to ensure data integrity and privacy. However, the physical security of these devices is entirely the responsibility of the customer. Unauthorized access to or tampering with the hardware can compromise the system and potentially expose sensitive data.

To maintain the highest level of data security, customers must ensure that all devices are installed in secure, access-controlled locations and inspected regularly for signs of interference. Failure to adequately protect the physical hardware may lead to vulnerabilities that cannot be mitigated through software alone. Therefore, physical safeguarding is a critical aspect of the overall security posture of your deployment.

2. Sensorfact Software

The Sensorfact Software is a cloud-based platform that gives you access to your measurement data.

Logging in

You can log in with your Sensorfact account at app.sensorfact.eu. We have sent you an e-mail with login instructions, with the subject "Your Sensorfact account has been created". If you did not receive this email, please also check your spam folder. If activating your account does not work out,, please try to reset your password via [this link](#). If this also doesn't work, contact your onboarding representative or support@sensorfact.nl.

Viewing data

On the left-hand side, you will see the machines and the groups from the inventory list you provided. If you have installed the bridges and sensors, and selected them in the left column, you will see your data coming in within minutes.

[Go to www.sensorfact.eu/help](http://www.sensorfact.eu/help)
for the Sensorfact Software instructional video

Installation feedback

To ensure a reliable installation of your Sensorfact energy management system, it is highly advised to use our installation status overview. You can check the connectivity status on the installation tab of the Sensorfact software. Go to the platform: Login >> User Icon >> Status.

Here you will find:

- Information about the network connectivity strength of your bridge(s).
- The strength of the connection between the sensors and the bridges.
 - For optimal functionality, the connection between bridge and sensor preferably has a **blue or green** colour (3-4 dashes).
 - If this connection is indicated with a red or yellow colour (1-2 dashes), your measuring system may not function optimally.
- The possibility to change the name of your sensor. You can easily change the name by clicking on the pencil icon in the same row as the sensorname + sensorID. If you would like to change your groups, please contact support@sensorfact.nl with the sensorID's and preferred groups.

If you have not been able to complete the installation successfully after using this overview, please contact your Onboarding Representative.

3. Bridges

A bridge has three antennas, a power cable and a 5V adapter. The bridge receives the data from the sensors through a wireless, industrial EnOcean connection. The bridge (temporarily) stores this data and uploads it to our cloud platform via a network connection. This network connection can be provided by means of an Ethernet cable, Wi-Fi or an LTE/4G (mobile network) connection. The bridge also has a LED light that indicates the connection status; this LED is located on the same side as the power cable.

Sensorfact can supply one of the two bridges shown below. The bridges have equal functionality and performance but the locations of the antenna and power ports are slightly different.



PLEASE NOTE!

To ensure correct functionality of the Sensorfact energy management system, please take the following guidelines into account:

- Place the bridge as close as possible to the sensors;
- Make sure that there are **no** large obstacles such as a large machine and/or wall between the bridge and the transmitter of the sensors. This can result in signals from the sensors not being received properly by the bridge;

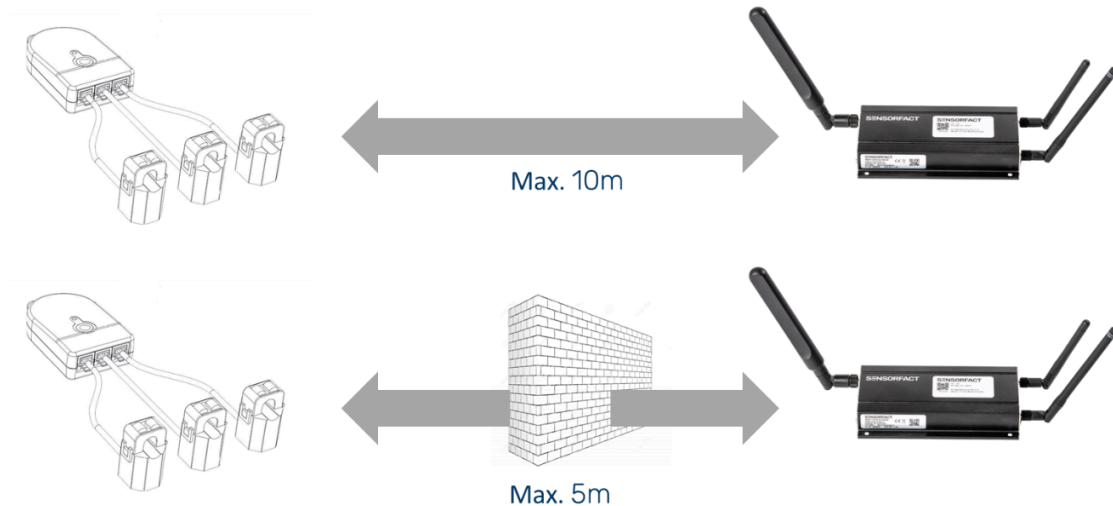

- The bridge has a white sticker on top with the text: 'bridge ID: XXXX'. This is essential information in case of questions about this bridge;
- Make sure you do not attach any mounting material over the stickers of the bridge;
- Make sure a power socket is available for the bridge;
- Do **not** place the bridge in a distribution cabinet. This is important or else the Internet connection via Wi-Fi or LTE (4G) might not be established properly;

Installation steps

1. Attach each antenna (EnOcean-, Wi-Fi -and LTE-antenna) to the appropriate socket in the bridge. **Please mount all 3 antennas to ensure optimal functionality of the system.**

A. Place the EnOcean antenna by screwing it to the bridge near the label 'EnOcean' or 'Sensors'. The EnOcean antenna is:

- a thin antenna with two grey stripes at the end.



- or a long, tapered antenna.



B. Install the LTE antenna by screwing it to the bridge at the 'LTE' label. The LTE antenna is a thick, semi-flat antenna.



- C. Install the Wi-Fi antenna by screwing it to the bridge near the label 'Wi-Fi'. The Wi-Fi antenna is the shortest antenna.



2. Plug the power cable into the 5V adapter at the USB input. Plug the other side of the power cable into the bridge.
3. Fixate the bridge with the mounting materials.
4. The power adapter can now be plugged into the socket.
5. Check the LED to see if the bridge is connected. The LED can transmit the current status in three different ways:
 - A. Continuously red: Installation is successful, the bridge has connected with the Sensorfact platform;
 - B. Flashing green: Disk activity is taking place, for example for writing measurement data;
 - C. Flashing red: The bridge is trying to connect to the network.

When a bridge is connected to the network, it can take about 20 minutes for the bridge to connect. In exceptional cases, it may take longer. You can continue to install the other bridges while the bridge is connecting.

6. Congratulations! The bridge is now installed, repeat the above steps for all other bridges in the box.

4. Current sensors

A current sensor consists of a transmitter module with three (or one if you use a single-phase sensor) separate clamps. The sensor relies on 'energy harvesting' from the power cables of the machines and thus does not need an external power supply.

The transmitter module sends the measurement data to the bridge. To be able to interpret the data correctly in the dashboard, it is important that you connect the correct sensors to the designated machines on the inventory list. You can identify the sensors using the 8-digit sensor ID.

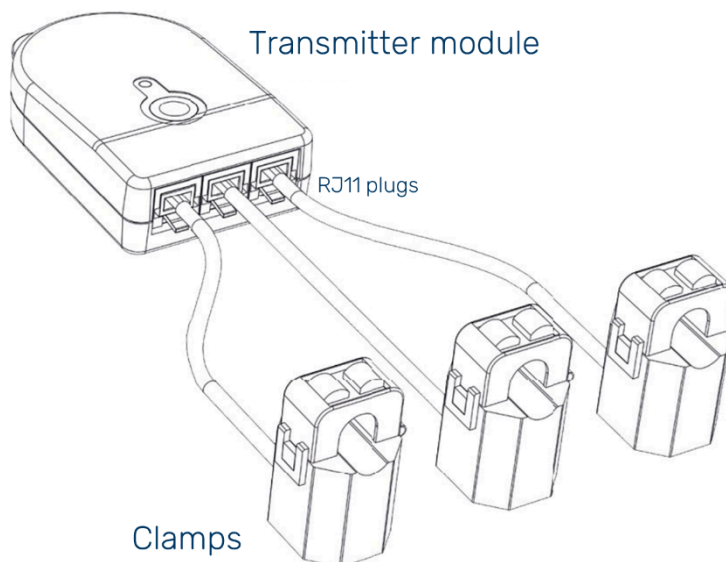

Installation steps

1. Take a sensor (transmitter module + 3 clamps) and read the sensor-ID. Find the sensor ID on the inventory list and go to the power cables of the corresponding machine.
2. Check that the metal parts of the clamp are free of dust and dirt. If this is not the case, wipe them clean with a cleaning cloth.
3. Click a clamp around every phase of the power cable and make sure that they are securely fastened by checking the snap closures; this prevents discharge vibrations. If the clamp does not fit around the cable properly, please contact our support.
4. Should a machine be powered through more phases than can be measured, it is sufficient to only attach the clamps where possible. In this case, it is **very important** to inform our support department of the number of power cables in total and the number of power cables with clamps, so that the data is processed in the appropriate way.
5. Click the RJ11 plugs (i.e. telephone sockets) of the clamps into the transmitter model. The order in which these are connected is not important.
6. After installation, check that the sensor is working properly by checking the LED light. If the transmitter light flashes every 10 seconds, the sensor is working properly.
7. **Note:** if the machine is not switched on or disconnected from the power supply, the LED light will not flash. The intensity of the LED light is low, this can be difficult to see.
8. If possible, mount the transmitter outside the distribution cabinet. Metal and concrete obstacles can significantly reduce the range of

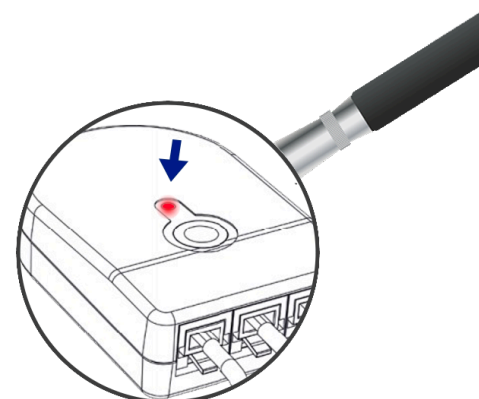
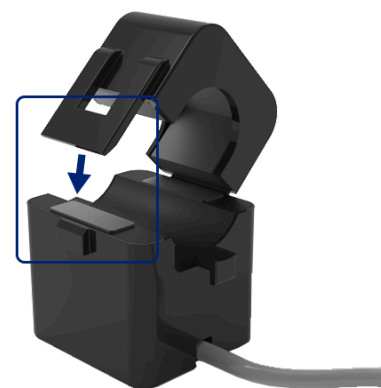

the wireless transmitter. If this is not possible, make sure that a bridge is placed close to the cabinet. Mounting can be done with double sided tape, screws, bolts or tie wraps.

9. To ensure that a decent connection between the bridge and a sensor is established, use the status overview. This functionality is described in chapter 2.
10. Congratulations! The sensor is now installed, repeat the above steps for all other sensors in the box.

If the data in the software seems incorrect, it's likely the software settings don't fully correspond with the actual voltage and power factor of the power supply. In the 'Analysis' tab, click the 'i' button next to a machine name to check these values.

Sensorfact can change these settings.

5. Pulse sensors

The pulse sensor and Sensorfact Software are designed to continuously register consumption data by monitoring a pulse output from a different utility meter. The pulse sensor sends a wireless message to a bridge once it registers a pulse – or – when it does not register any pulse within a single hour. Subsequently, following the correct volume or power coefficient (i.e. # of pulses per m³), the Sensorfact Software logs the data and shows the consumption over time.



Basic functionality of the pulse sensor

Determine the suitable connection method

There are different methods to connect your meters to the pulse sensor. The suitable method follows from the brand and type of meter you have installed. In the *connection advice* you receive from Sensorfact, the method that works with your meter is explained.

Possible connection methods	
Meter cable with pulse output (3mm to 6mm) - Already part of your meter	
DIN-cable , fitting to your meter's pulse generating DIN-socket - Delivered by Sensorfact - Selection of <u>2 Pins</u> to connect, advised by Sensorfact - In case of multiple DIN-sockets, Sensorfact advises which one to use	
Pulse generator generating a pulse output signal, often by monitoring the number of rotations of the meter - Brand and type is advised by Sensorfact - If required: selection of <u>2 Pins</u> to connect, advised by Sensorfact - A Pulse generator comes with a separate manual	

Items needed for installation

If you install pulse sensors, you will also need:

- A cross head screwdriver (for pulse sensor lid)
- A small flat blade screwdriver (for pulse sensor internal terminals)
- Wire stripper or cable-knife
- If advised upon and delivered by Sensorfact: DIN-cables
- If advised upon; pulse generators

Installation steps

Step 1: Open lid

Start by opening the lid of the pulse sensor with a PH2 screwdriver. You will see the below:

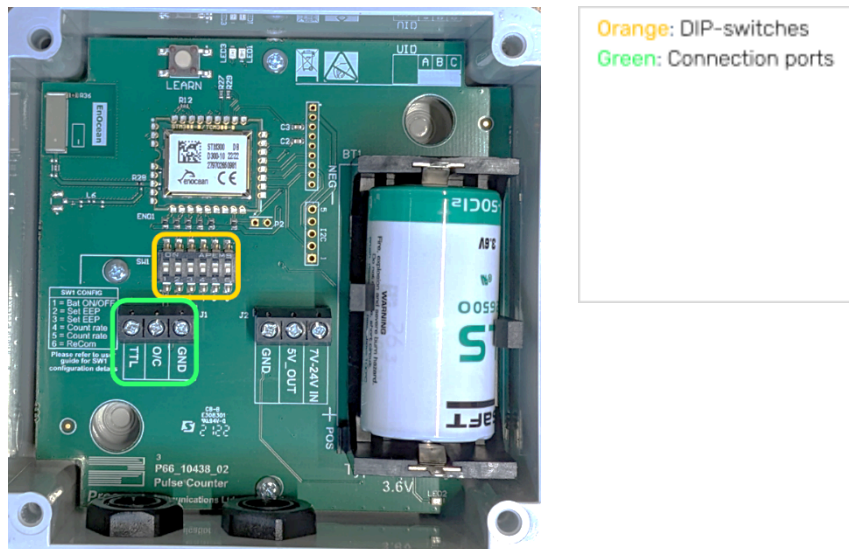

Step 2: Insert and fasten the connection cable

The cable entry glands of the pulse sensor are designed for the entry of a 3mm to 6mm cable. Only use the left entry gland. To ensure the sealing effectiveness level (IP-classification), ensure that the cable only splits at the inside of the sensor, not at the outside.

- When a DIN-cable or pulse Generator is used, cross-check the *connection advice* before installation. The advice shows the selected pins(colour) to connect to the connectivity ports.
- Before inserting, strip the wires / pins to enable connectivity
- Make sure the gland is fully tightened after inserting the cable

The connection block on the pulse sensor circuit board has screw ports. To fasten the cables, use a small flat blade screwdriver. The selected two pins of the cable should be connected to the terminals marked **O/C** (Open/Close) and **GND** (Ground). The polarity/order of the connections does not matter here.

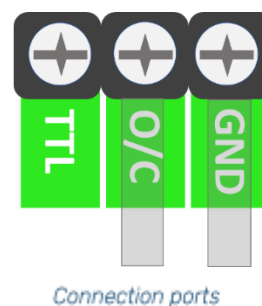
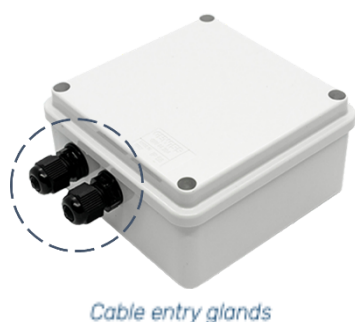

Step 3: Activate power by moving DIP-switch 1

By changing the position of *DIP-switch 1* to ON (by moving it upwards), you activate the pulse sensor battery. After doing so, close the lid. Do not change the position of DIP switch 2 – 6 upwards, unless Sensorfact suggests you to do so. These switches can impact the calculation of your data.

Activate pulse sensor battery

1	2	3	4	5	6
<u>ON</u>	OF	OF	OF	OF	OF
	F	F	F	F	F

Step 4: Check whether data shows in software

Before mounting, check whether:

- Sensor shows as online (green) in the 'Installation' tab of the software.
- Correct data shows in software.

If the sensor or data is not or incorrectly shown, follow the troubleshooting guide.

Step 5: Mount pulse sensor

The casing of the pulse sensor can be mounted via the outside with the sticky pads and via the inside with the screw kit (which accompanies O-pads for additional IP-protection). We recommend mounting it on a vertical non-metallic surface, with the cable entry gland facing downwards. Do not wrap the applied cable around other cables, as this can cause electrical interference to the pulse output.

When choosing the location for mounting the sensor, avoid placing the device on a metal surface. This would affect the signal strength between the sensor and the bridges.

Additional commissioning (only if advised by Sensorfact)

In very specific cases, additional commissioning will be needed. If so, Sensorfact will let you know within the *connection advice*. If nothing is mentioned about this, you can fully neglect this paragraph and should not follow the below actions.

Change DIP switches in case of high frequency

The DIP settings should change as below when the pulse Frequency is higher than 1 Hertz. After changing the settings, press the learn button while the battery is inserted. Subsequently, the LED right from the learn button should blink as confirmation.

(MF) pulse frequency 1 Hz to 6 Hz

1	2	3	4	5	6
<u>ON</u>	OFF	OFF	OFF	<u>ON</u>	OFF

(HF) pulse frequency 6Hz to 12 Hz

1	2	3	4	5	6
<u>ON</u>	OFF	OFF	<u>ON</u>	OFF	OFF

Press 'learn' button after changes

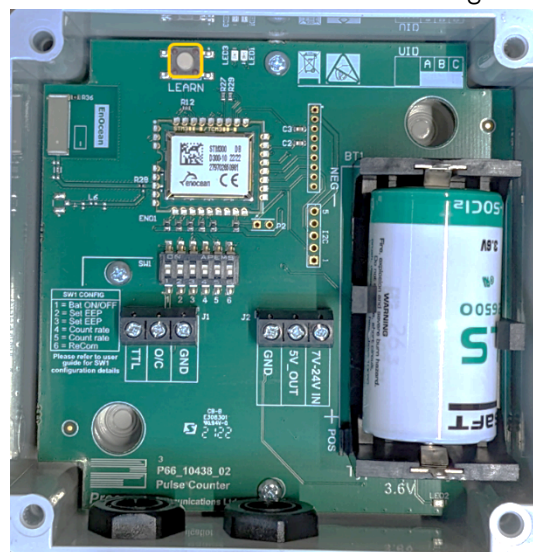

If the data in the software is not correct – seemingly the software settings don't fully correspond with the volume or power coefficient of your pulse output. Contact your Onboarding Representative or e-mail support@sensorfact.eu.

6. Troubleshooting guide

If the installation cannot be completed with the below guide, and additional help is needed, contact your Onboarding Representative or email support@sensorfact.eu.

Installing bridges	
Issue	Checks to perform and possible solutions
<p>Bridge will not come online</p> <p>bridge is fully powered by adapter and LED keeps flashing red</p>	<ul style="list-style-type: none"> • Are all 3 antennas correctly and firmly connected? • In the case of Wi-Fi or 4G, is the network strength on the location of the bridge strong enough? If possible, check signal strength on a mobile phone near the location of the bridge. • In case of a secured ethernet or Wi-Fi network (see Chapter 1) <ul style="list-style-type: none"> o Are the correct IP-addresses opened up? o Are MAC addresses needed and if so, registered? • Is the bridge covered or surrounded by concrete, metal pipes or a metal casing? <ul style="list-style-type: none"> o If so, move the bridge to a location without such surroundings. • Is the bridge installed close to a frequency inverter? <ul style="list-style-type: none"> o If so, move the bridge as far away (>2m) from the frequency inverter as possible.
Installing current sensors	
Issue	Checks to perform and possible solutions
<p>Sensor ID does not show in 'installation' tab</p>	<p>Contact support@sensorfact.eu to ensure correct registration of the sensor to your account.</p>
<p>Sensor ID shows, but no signal in 'installation' tab.</p> <p>No measurement shows in <24 hours</p>	<ul style="list-style-type: none"> • Is the machine switched on? (the sensor is powered by the power cable of the machine) • Is the sensor properly clicked onto the power cable? Can you open and close the sensor? • Is the sensor in range of a bridge, without obstacles between the bridge and the sensor (see chapter 3)? • Are all 3 antennas correctly and firmly connected to the bridge? • Is the sensor installed close to a frequency inverter? <ul style="list-style-type: none"> o If so, move the bridge as far away (>2m) from the frequency inverter as possible. <p>If the sensor has not come online after completing the above steps, please place it where another working sensor is / was mounted to test whether this might be a defect sensor.</p>

<p>Wrong data shows in 'analysis' tab</p>	<ul style="list-style-type: none"> • If the data in the software is not correct – seemingly the software settings don't fully correspond with the voltage and power factor of the power supply. In the software 'power' tab, click the 'i' button next to the machine to check this. <p>Sensorfact can change these settings if needed.</p>
<p>Doubts about sensor type</p> <p>Possibly wrong maximum fused power</p>	<ul style="list-style-type: none"> • Check the fused power (per phase) of the power supply to be measured. Our sensor types indicate the maximum amperage that can be measured with them: 60A, 200A or 600A per phase. • Alternative: check the power of the machine being measured. You can recalculate the current by dividing the power of the machine by the voltage (in Volts) and by a standard of 0.9. For example, a 50 kW machine connected to 230 Volt has a current of $50,000 / (230 * 0.9) = 242$ A.

Installing pulse sensors

<u>Issue</u>	<u>Checks to perform and possible solutions</u>
<p>Sensor ID does not show in 'installation' tab</p>	<p>Contact support@sensorfact.eu to ensure correct registration of the sensor to your account.</p>
<p>Sensor ID shows, but no signal in 'installation' tab.</p> <p>No measurement shows in <24 hours</p>	<ul style="list-style-type: none"> • Does the sensor ID show at one of the bridges in the 'installation' tab? • Is the selected bridge 5-10m distance from the pulse sensor, without obstacles in between? • Is the battery inside the pulse sensor properly placed and DIN-switch 1 turned ON?
<p>Wrong data shows in 'analysis' tab</p>	<ul style="list-style-type: none"> • Are steps 1, 2 and 3 of the manual followed and is the pulse sensor connected following the received connectivity advice? • Are the cables connected to the correct ports on the pulse sensor? (O/C, GND)? • Are the pins with the correct colours connected to the ports? • Is the output cable wrapped around other existing cable in the factory? • In case of a pulse generator, is the manual of the generator followed?

SENSORFACT